

Flue Gas Desulfurization System Expansion Design Optimized with AFT Arrow™

*Platinum Pipe Award 2008 Winner – Use of Software Features & Model
Creativity/Appearance Categories*

Company: Energoprojekt Katowice
Address: Jesionowa 15
 Katowice, Silesia 40-159
 Poland
Telephone: +48-032-2089-295
Fax: +48-032-2089-295

Energoprojekt Katowice is a leading engineering firm providing design services for conventional power plants, thermal power plants and heating plants.

Energoprojekt Katowice was charged with designing the expansion of the flue gas desulfurization system at a coal fired power plant in Poland. Originally having a capacity equivalent to four of the eight power units at the plant, increasing environmental regulations required a capacity expansion to now handle all eight power units.

The system presented several unique challenges to accurately model its characteristics, all ingeniously addressed by Energoprojekt's engineer, Adam Klepacki:

- The natural draft effect in the discharge stacks provides a noticeable and useful benefit in assisting system flow that varies as a function of the gas flow rate and temperature. Using fans modeled with curves, the draft effect as a function of flow was accurately simulated. By modeling the fans using Multiple Configurations, curves for the flue gas temperature extremes were represented in a single 'fan' making it easy to change operating scenarios by simply selecting the curve corresponding to the 'hot' or 'cold' flue gas.
- The FGD plants have the combined effect of increasing the gas stream temperature and adding mass and volume to the flow by virtue of the internal water spray. Using a heat exchanger with a controlled downstream temperature in conjunction with spray discharge junction this combined effect on the flue gas flow stream was simulated.
- Induced draft (ID) fan speed control to maintain a controlled furnace exit pressure was simulated using the Arrow GSC Module. With the multitude of ID fans and furnaces, this represented an 8 variable/8 goal automated goal seeking operation saving significant time compared to a manual iteration.
- Flue gas conduits in power plants typically have very large cross sections so that the velocity profile is highly irregular, with significant turbulence induced by direction changes resulting in hydraulic resistance larger than the resistance calculated based on the

mean velocity. To account for this ducting resistance was increase using a combination of additional fittings losses an increased wall roughness.

- The unique properties of the flue gas were dynamically modeled by characterizing its properties within an AFT Arrow fluid database.

In commenting on the benefits achieved by modeling this complex system with AFT Arrow, Mr. Klepacki said; "It would be very difficult and time consuming to calculate such a big system using only pencil and a piece of paper or even a calculator. To solve this task I needed specialized software which can estimate all necessary flows and pressures in every branch of the system (moreover, using GSC module I could set the demand pressure in the furnace chamber). Using AFT Arrow I could check all parameters and find the optimal dimensions of conduits in order to deliver the required flow through the FGD plants. Another very important aspect is when we are to introduce changes. There is no problem when you have such a model because every change in design data can be easily implemented and new results are available in a few minutes. The same is true when multiple scenario analysis is needed (in my case I have calculated about 40 scenarios so it has brought me a really great benefit). Furthermore, I could determine how large a compression reserve there is in the ID fans and auxiliary fans in order to be sure that even when the calculations have some uncertainties the whole installation will operate properly."

General	Warnings	Compressor/Fan Summary		Valve Summary		Heat Excha
Jct	Name	Mass Flow (Nm3/h)	Vol. Flow (m3/hr)	dP Static (Pascals)	dP Stag. (Pascals)	Overall Power (kW)
20	Compressor/Fan	430,737	700,324	3,030	3,142	601.6
21	Compressor/Fan	473,320	769,607	3,007	3,142	661.1
22	Compressor/Fan	451,996	734,911	3,288	3,411	684.8
23	Compressor/Fan	451,996	734,911	3,288	3,411	684.8
24	Compressor/Fan	452,002	735,295	3,269	3,328	668.3
25	Compressor/Fan	452,002	735,295	3,269	3,328	668.3
26	Compressor/Fan	451,998	735,290	3,291	3,350	672.6
27	Compressor/Fan	451,999	735,290	3,291	3,350	672.6
32	Compressor/Fan	452,002	735,295	3,265	3,324	667.5
33	Compressor/Fan	452,002	735,295	3,265	3,324	667.5
39	Compressor/Fan	452,007	735,303	3,126	3,185	639.8
40	Compressor/Fan	452,007	735,304	3,126	3,185	639.8
48	Compressor/Fan	452,011	735,309	3,052	3,111	625.2
49	Compressor/Fan	452,011	735,309	3,052	3,111	625.2
54	Compressor/Fan	451,995	735,284	2,928	2,987	600.6
55	Compressor/Fan	451,995	735,284	2,928	2,987	600.6

Compressor/Fan Summary from one of the many operating scenarios simulated.

Detail view of the FGD plant and discharge stack area of the system

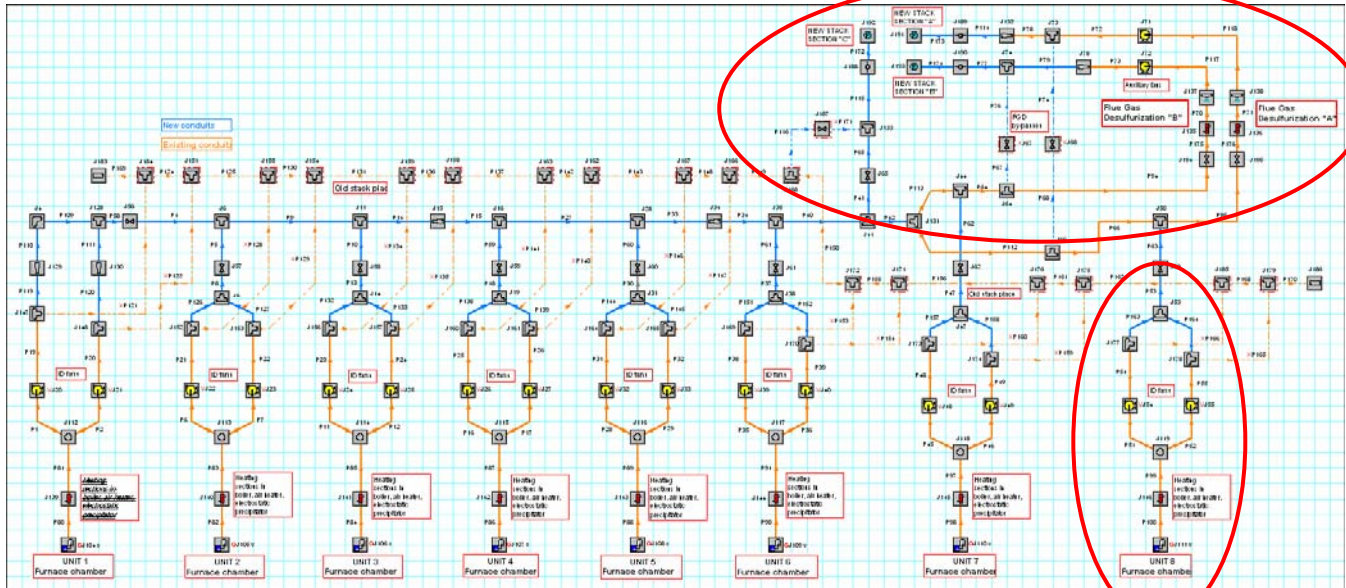
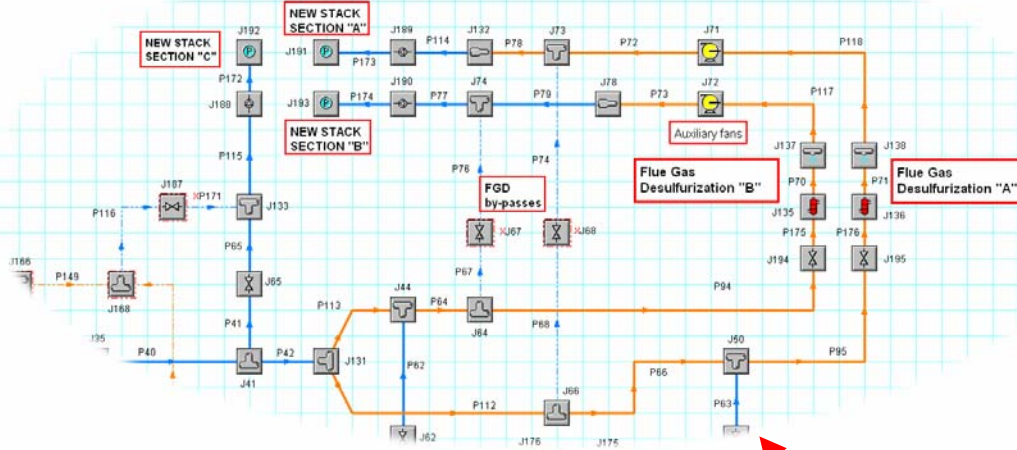

Typical ID fan arrangement

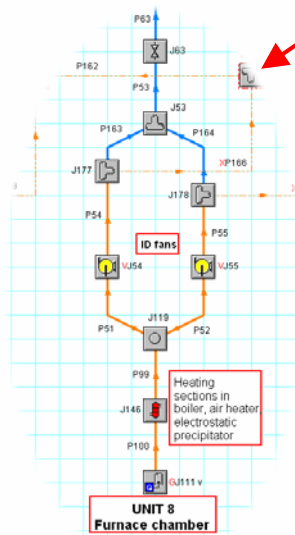

Applied Flow Technology
 Design with intelligence. Build with confidence.™

For more information on AFT Fathom, contact Applied Flow Technology at (800) 589-4943 or visit our website at www.aft.com.